

APPENDIX C – 90% VEHICLES

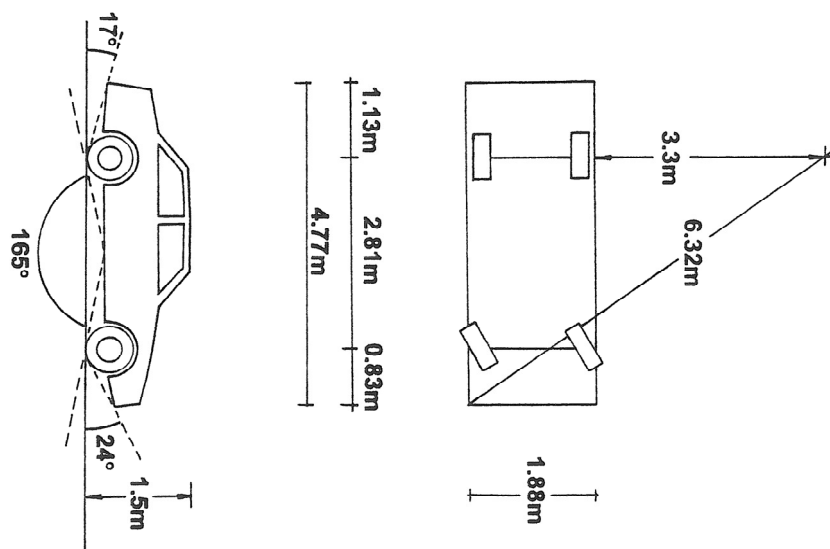

90% Design Motorcar Scale 1:100

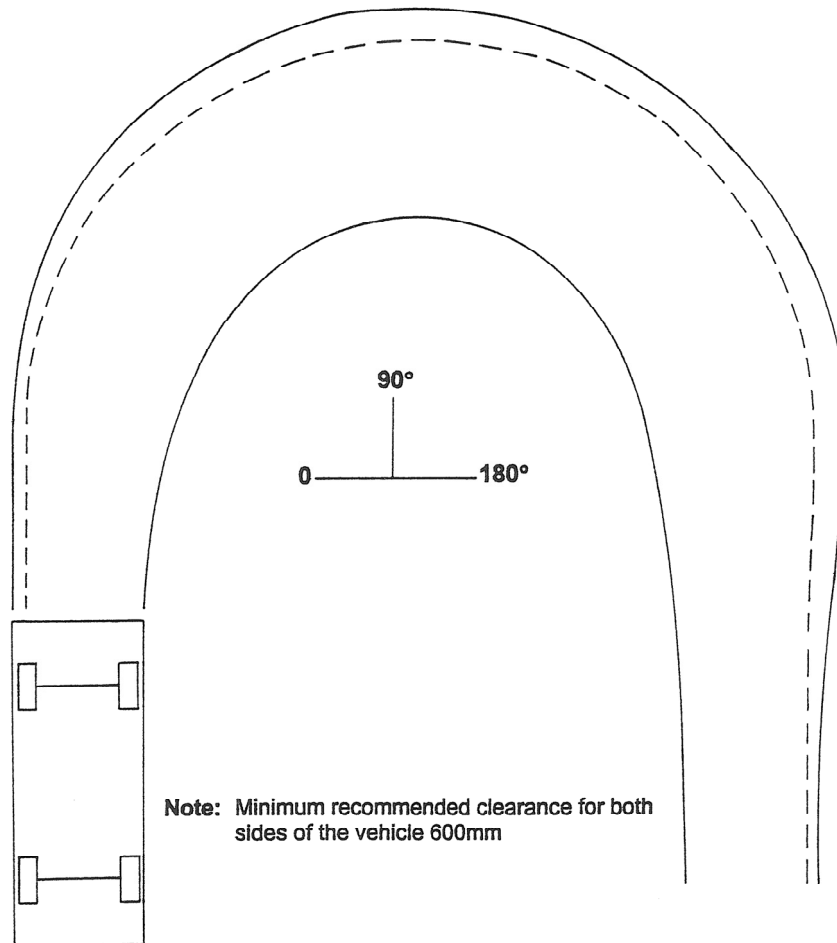
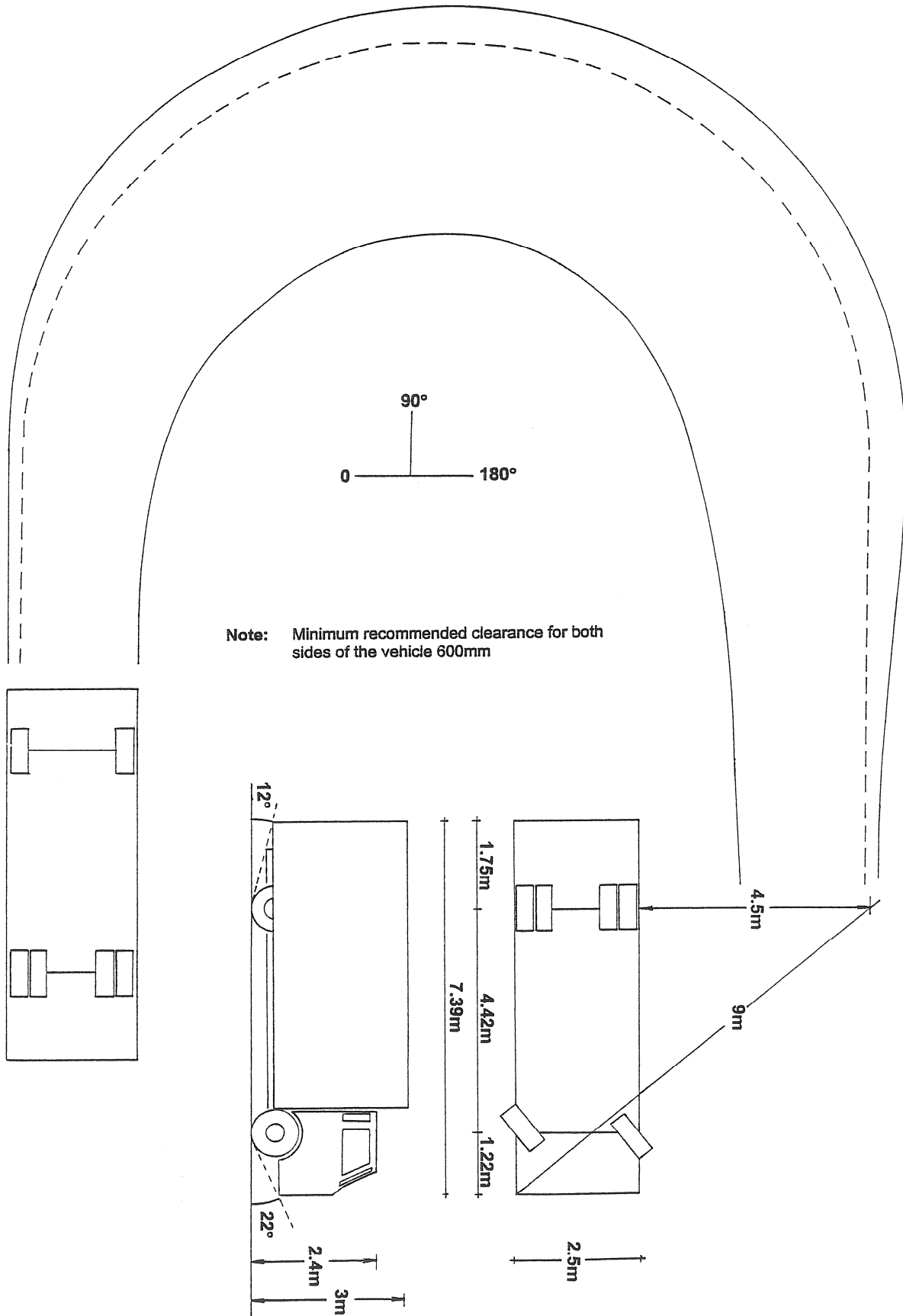

Design 2 Axle Truck

Scale 1:100

Reduced Copy

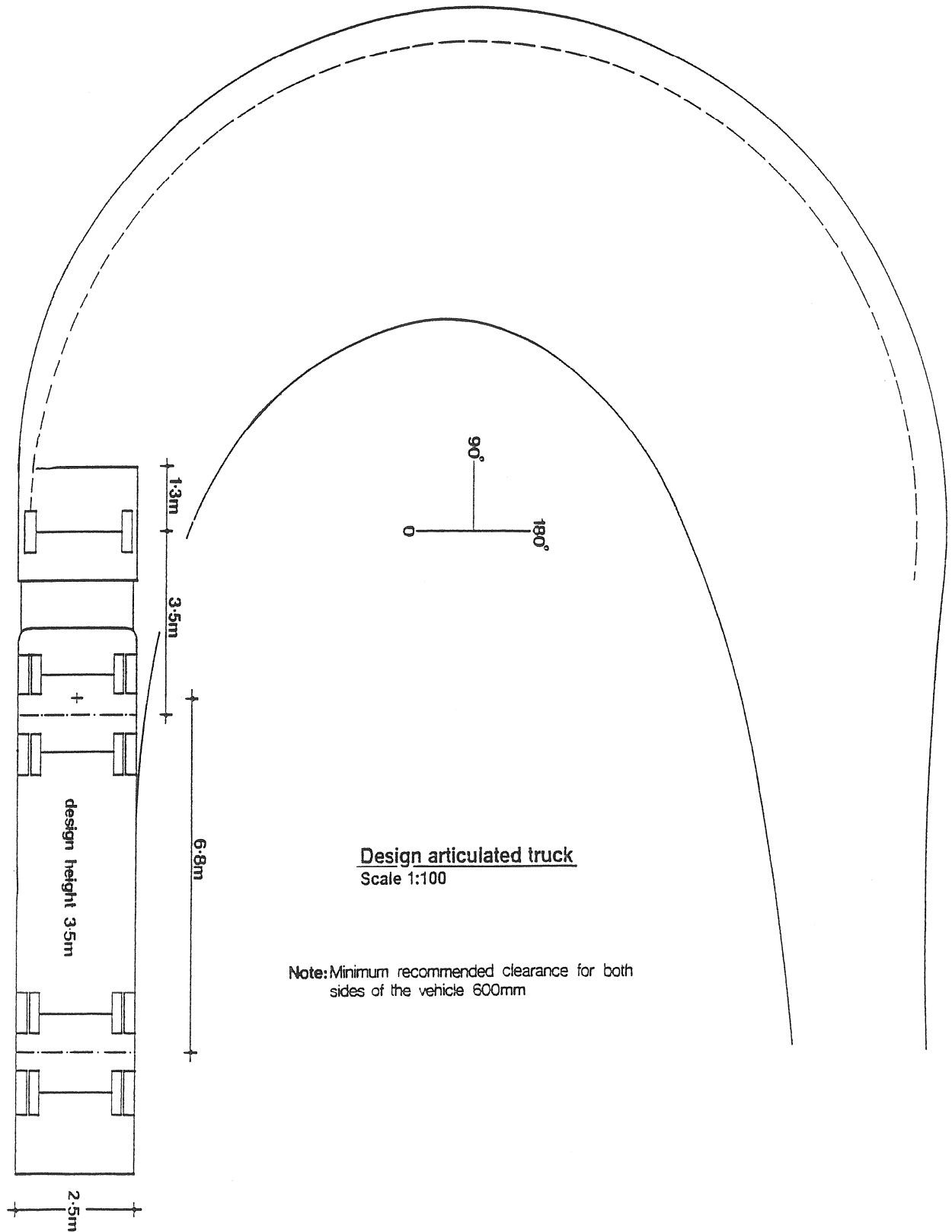

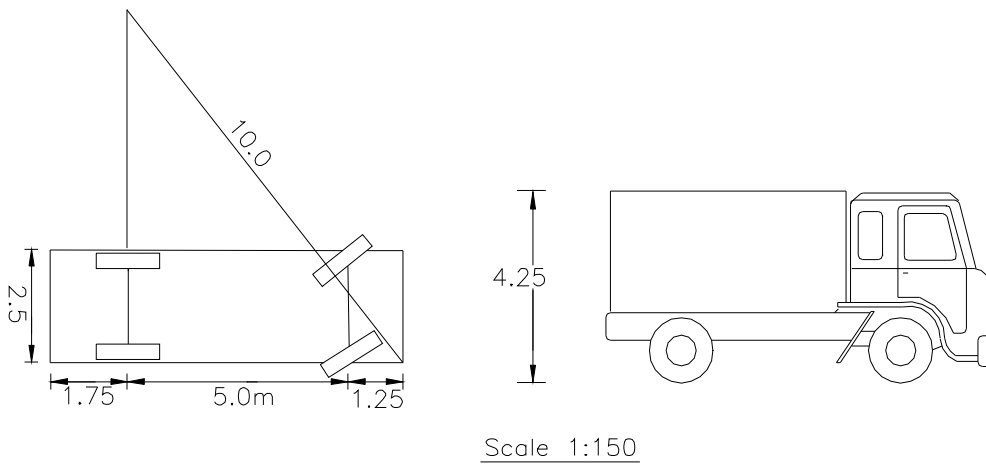
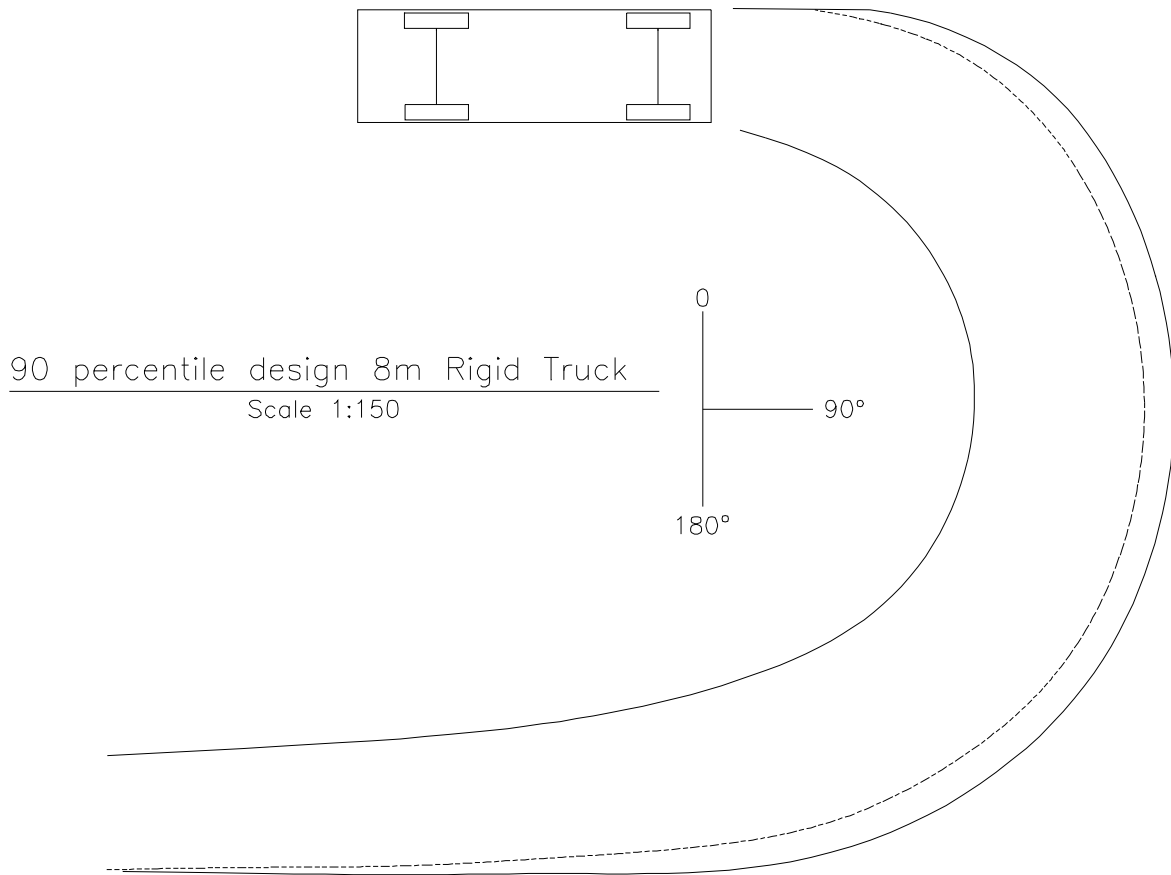

Note: The absolute minimum ground clearance excluding mudflaps is 100mm. At any point along the vehicle, the ground clearance shall be at least 1/10 of the distance from the nearest axle to the point where the ground clearance is measured

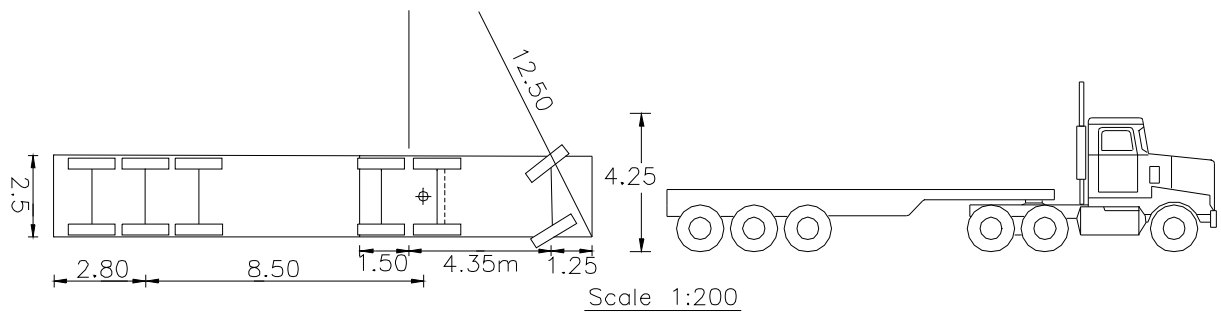
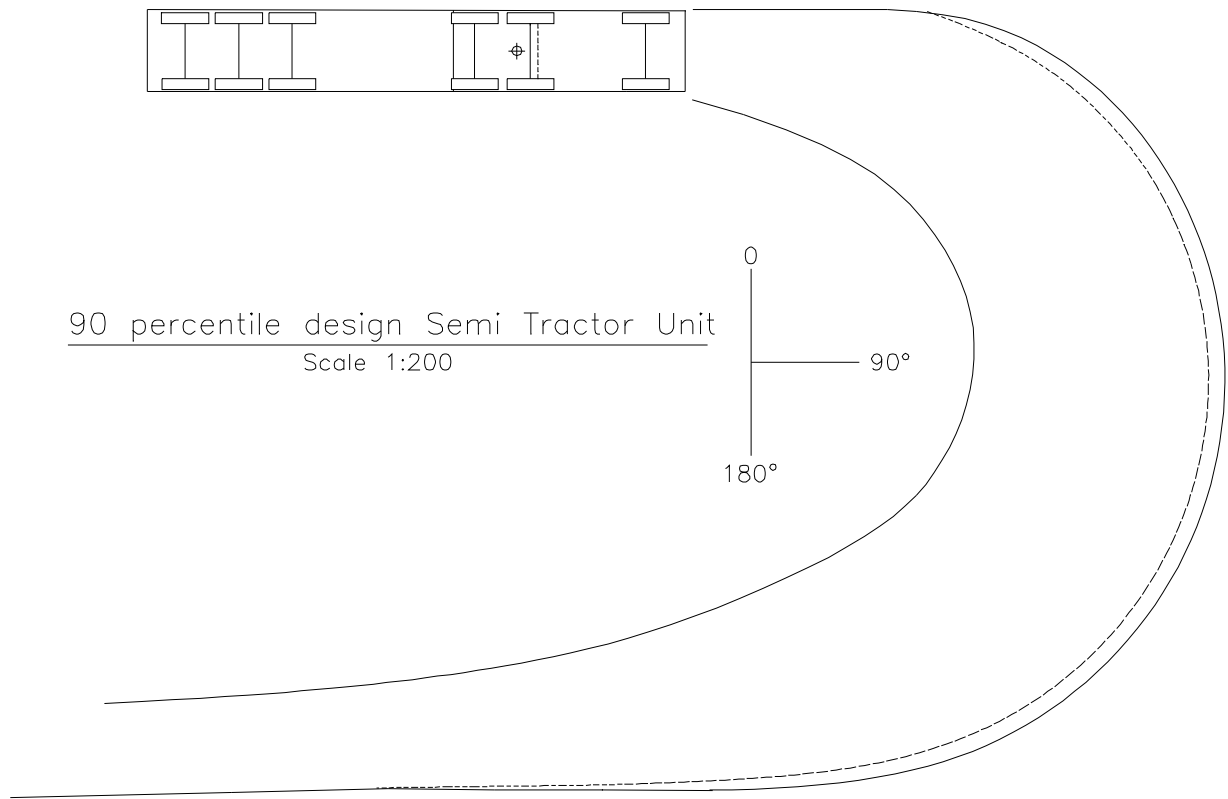

Note: The absolute minimum ground clearance excluding mudflaps is 100mm. At any point along the vehicle, the ground clearance shall be at least 1/10 of the distance from the nearest axle to the point where the ground clearance is measured

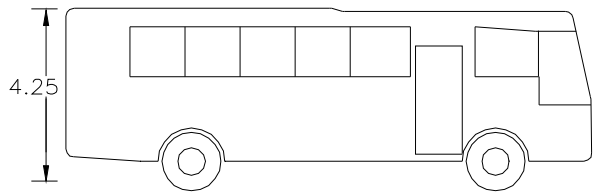
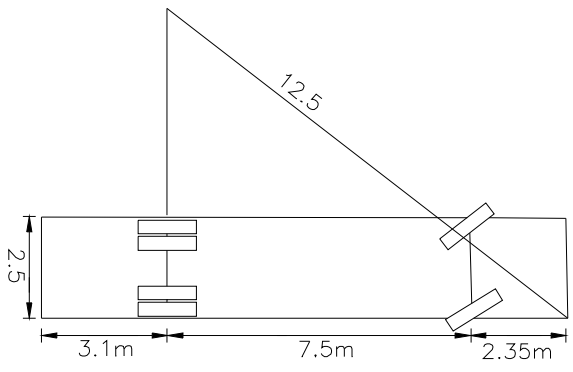
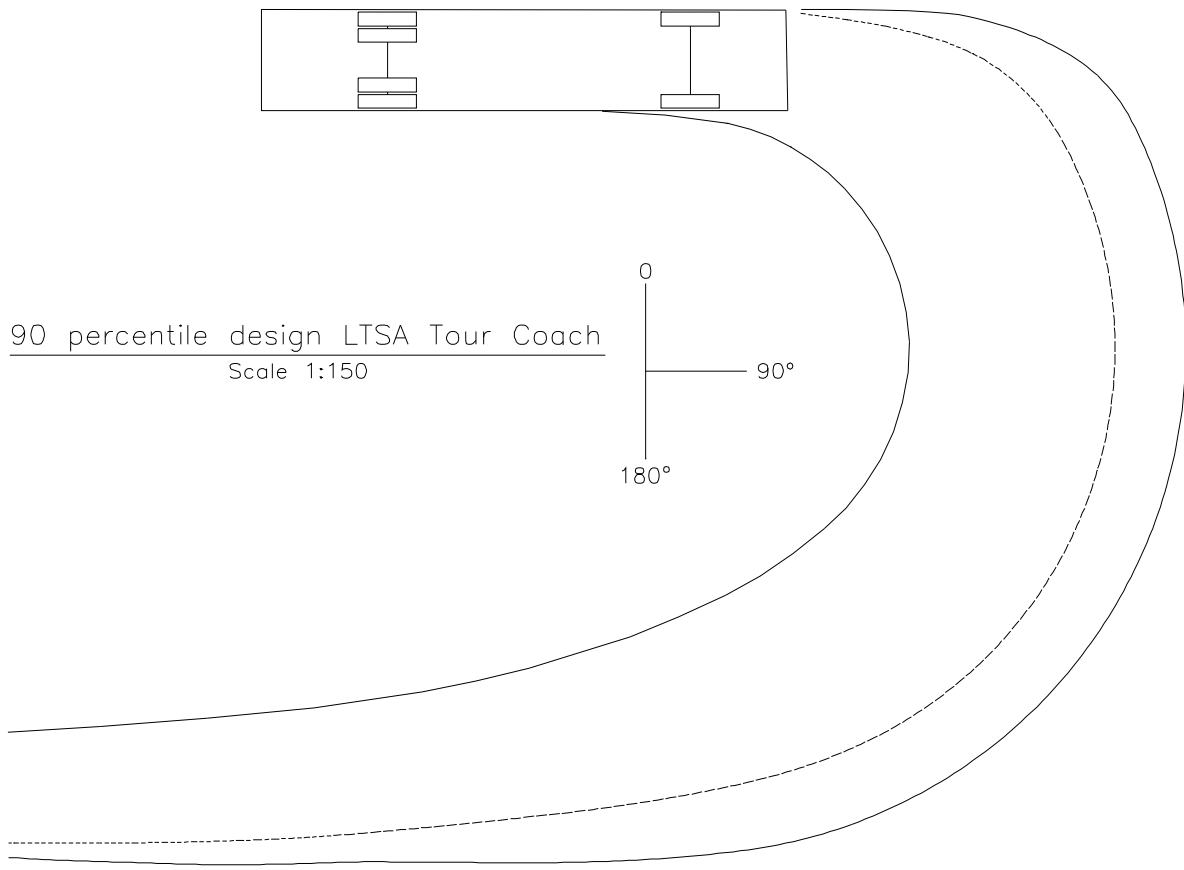

Scale 1:150

Note: The absolute minimum ground clearance excluding mudflaps is 100mm. At any point along the vehicle, the ground clearance shall be at least 1/10 of the distance from the nearest axle to the point where the ground clearance is measured